

# **OMEM 550**

## Hardware Instructions

<b>1</b>	<b>Introducing Omex Engine Management .....</b>	<b>4</b>
1.1	Notation Used in This Manual .....	4
<b>2</b>	<b>Quick Start .....</b>	<b>5</b>
2.1	Software .....	5
2.2	Trigger Wheel.....	5
2.3	Wiring .....	5
2.4	Throttle Position .....	5
2.5	MAP Sensor .....	6
2.5.1	1 bar Sensor .....	6
2.5.2	2 and 3 bar Sensor.....	6
2.6	Sensor Testing .....	6
2.7	Timing .....	7
<b>3</b>	<b>Sensors .....</b>	<b>9</b>
3.1	Timing .....	9
3.1.1	Magnetic Variable Reluctance Sensor .....	9
3.1.2	Trigger Wheels .....	9
3.1.3	Distributor Triggering.....	10
3.2	Load .....	10
3.2.1	TPS.....	10
3.2.2	MAP.....	10
3.3	Temperature.....	10
3.3.1	Air Temperature Sensors .....	10
3.3.2	Coolant Temperature Sensors .....	10
3.4	Barometric.....	10
3.5	Oxygen (Lambda) Sensor .....	11
<b>4</b>	<b>Ignition.....</b>	<b>12</b>
<b>5</b>	<b>Fuelling.....</b>	<b>13</b>
5.1	Injectors.....	14
5.1.1	Sizing.....	14
5.1.2	Scaling.....	14
	Battery Compensation .....	15

5.2 Warm up Fuel.....	17
<b>6 Oxygen Feedback.....</b>	<b>18</b>
<b>7 Transient Fuelling.....</b>	<b>20</b>
7.1.1 Acceleration Fuel.....	20
7.1.2 Deceleration Fuel Cut Off.....	20
<b>8 Idle Stabilisation .....</b>	<b>21</b>
<b>9 Cranking.....</b>	<b>22</b>
9.1 Cranking.....	22
9.2 Cranking Fuel.....	22
<b>10 Auxiliary Output.....</b>	<b>23</b>
10.1 Fuel Pump Controller .....	23
10.2 Tacho Controller.....	23
10.3 Shift Light .....	23
<b>11 Options List.....</b>	<b>24</b>
<b>12 Parameters .....</b>	<b>27</b>
<b>13 Wiring .....</b>	<b>28</b>
13.1 Semi Assembled Loom Construction .....	28
13.2 Component Pin-outs.....	29
13.3 ECU Pin-outs.....	30
13.4 Wiring Diagrams.....	31

# 1 Introducing Omex Engine Management

Thank you for choosing Omex Engine Management. This manual is written to help the user through the specifics of the OMEM550 ECU. **It is essential that the user reads all of the Omex manuals before attempting to install the system and before attempting to start the engine.** Incorrect use of the Omex system could potentially lead to damage to the engine and personal injury. If you have any doubts about fitting these parts or using the software then please contact Omex for help.

As the system is computer based, technical support is given on the assumption that the user is able to perform simple Windows based operations.

Omex may not be held responsible for damage caused through following these instructions, technical, or editorial errors or omissions. If you have any doubts about fitting these parts or using the software then please contact Omex for help.

## 1.1 Notation Used in This Manual

Menu commands are signified in bold type with a pipe symbol | between each level of the menu.

For example, **File | Open** indicates that you should click on the **Open** option in the **File** menu.

**UPPER CASE TEXT** is used to indicate text that should be typed in by the user.

## 2 Quick Start

This manual has been written to give all of the technical information required to map an engine and set up various controls such as lambda and idle. Most users however, only need to get the engine to the point where the vehicle can be carefully driven to a dyno, so this 'quick start' chapter has been written to direct you through the procedures needed to achieve this. It is still recommended that you read the manual in full before attempting to use your Omex ECU, but the following information will help you with the practicalities of setting up your system.

### 2.1 Software

- Install MAP2000 software onto your computer as described in the software manual. For more information about using the software refer to the software specific manual.
- If supplied with a startup map, save this map to the c:\Program Files\MAP2000\Calibrations folder.

### 2.2 Trigger Wheel

This is only applicable to engines using crank triggering for engine speed and position. If distributor triggering refer to section 3.1.3.

- Accurately mark TDC.
- Turn the engine to approximately 60° BTDC.
- Mount your crank position sensor (CPS) around the perimeter of the timing wheel pointing towards the centre of the wheel with a sensor to wheel gap of approximately 0.5mm.
- One of the teeth must face the crank position sensor at this point.

### 2.3 Wiring

Wire your semi-assembled harness as described in section 13. The injectors need to have their impedance tested as low impedance injectors must have the optional ballast resistors installed. See section 5.1 for more information.

### 2.4 Throttle Position

The throttle position sensor outputs a raw number to the ECU. The ECU needs to know what this number means in relation to throttle position. We therefore have to use the MAP2000 software to give the ECU the required information.

- Connect the data lead between the Omex ECU and your computer's coms port.
- Click on the **START** button



- Ensure the vehicle's ignition is off.
- Open **ECU | Connect** and then turn on the vehicle's ignition. Do not crank the engine. The ECU should now be connected live to the computer.
- The **Parameters** window should now have a number for **TPS raw**. At the idle position, the throttle pot needs to be physically turned until this number is around 20. Tighten the throttle pot then open to WOT (wide open throttle) and check the **TPS raw** number. This number should be less than 255. If the number is 255, then the throttle pot is at its stop so needs to be turned back until it reads less than 255.

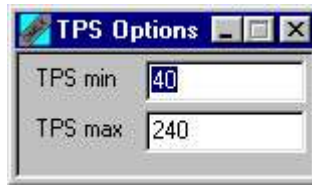

- The number for **TPS raw** at WOT needs to be inputted to the **TPS options** window as **TPS max**. The number for **TPS raw** at idle needs 4 taken from it, then inputting to the **TPS options** window as **TPS min**. In the **Parameters** window, **Throttle** should now read '1'. This is the number needed at idle NOT '0'. If the number shown is not '1' then change **TPS min** in the options table until it does. If the value of throttle reads '0', then this will give inconsistent idle. Therefore check that the value will always read '1' by snapping the throttle open and closed several times.

## 2.5 MAP Sensor

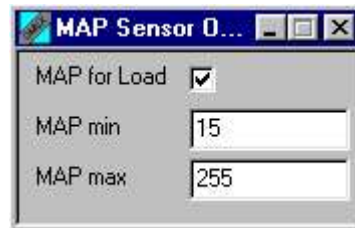

If fitted with a MAP sensor, then the MAP sensor will need calibration. The calibration varies depending on the range of the sensor. MAP sensor ratings are absolute rather than boost pressure so 1bar is for NA engines and barometric compensation, 2bar for up to 1bar boost, and 3bar for up to 2bar boost.

### 2.5.1 1 bar Sensor

- Enter a value for **MAP max** of 255.
- Enter a value for **MAP min** of 15.
- Vary **MAP min** until the engine has its idle on the 10% load site.

### 2.5.2 2 and 3 bar Sensor

- The value for **MAP max** can be calculated as follows.

$$\text{MAP max} = \frac{\text{Boost in psi} + 14.7}{14.7 \times \text{bar rating of sensor}} \times 255$$

This value should then have 10 added to it to allow for overboosts.

- Alternatively pump the sensor up to the maximum expected boost pressure and read off the value of **pressure raw** in the parameters window. Enter this number as **MAP max**.
- Enter a value of **MAP min** of 2 bar sensor = 15  
3 bar sensor = 5
- Vary **MAP min** until the engine has its idle on the 10% load site.

## 2.6 Sensor Testing

All of the sensors need to be tested before starting the engine. The inputs from the sensors can be seen in the **Parameters for Setup** window.

Parameters		
Locked		
Battery		volts
TPS raw		
Throttle		
Engine Speed		rpm
Spark Out		°
Coolant		°C
Air Temp		°C
Pressure raw		

As some of the sensors have been checked during calibration, there are only a few remaining. **Battery** is the battery voltage and should read between 9 and 16 v. The coolant and air temperatures should read sensible numbers, around room temperature if the engine has not been started. **Engine Speed** will show between 100 and 250 rpm under cranking. This can be checked when the timing is calibrated.

## 2.7 Timing

The ECU uses a crank position sensor and trigger wheel to sense engine speed and position. The ECU must therefore be told where the engine is in its cycle when it sees each tooth reference point.

- In the **CPS Options** window set **Delay Angle** to 15, as this value should be close enough to allow the engine to start.

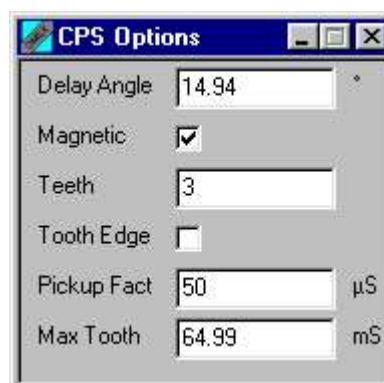

- Open **Idle | Idle Options**, to find **Hi Idle Adv** and **Low Idle Adv**.
- Take note of these values as they are the idle stabilisation values. They will at idle govern the ignition timing changes allowed to maintain idle so set them to 0 to stop them from moving the ignition timing rapidly.
- Start the engine. As the timing is not correctly set, and the fuelling is yet to be mapped, this may require moving the throttle to find a point at which it will start. When the engine has started, find a point above idle where the engine runs smoothly and **Spark Out** is stable. This would normally be above 2000rpm. If the engine appears to be particularly rich or lean throughout the

rpm range, then **MSPB** may need adjustment. For more detail on this, refer to section 5 and 11.

- Using a timing light, compare the value of **Spark Out** to the timing value shown on the light.
- As the value for **Delay Angle** option is changed, the value of **Spark Out** will remain constant, but the timing figure shown on the timing light will change. You are aiming to have the timing light reading the same value as **Spark Out**.
- Reset **Hi Idle Adv** and **Low Idle Adv** to the original values.

## 3 Sensors

### 3.1 Timing

The ECU needs to know engine speed and position in order to supply the correct fuelling and ignition timing. This is often achieved using the standard sensors, but can involve putting new sensors on the engine.

#### 3.1.1 Magnetic Variable Reluctance Sensor

Engine speed and position are sensed with a crankshaft mounted magnetic/reductance sensor. The sensor detects the movement of an iron tooth past its pole-piece. **Magnetic** in the options menu must be set to ON to use this type of sensor.

#### 3.1.2 Trigger Wheels

The crank trigger needs to provide one pulse per ignition event, ie

- 2 pulses / engine rev for a 4 cyl
- 3 pulses / engine rev for a 6 cyl
- 4 pulses / engine rev for an 8 cyl

The exact position of the first pulse is not critical as it can be adjusted in software but the second pulse must be **exactly x** degrees later and so on.

- 4 cyl  $x=180$
- 6 cyl  $x=120$  (as shown in diagram)
- 8 cyl  $x=90$

The easiest way to do this is either to machine the front pulley or to have a timing disc made up. Remember that the timing disc must be made from a magnetic material if you are using the magnetic pickup (the preferred option for most engines). You will need to arrange for raised notches as below. Slots in the pulley can work but can be unreliable unless the machined finish of the pulley is very good.

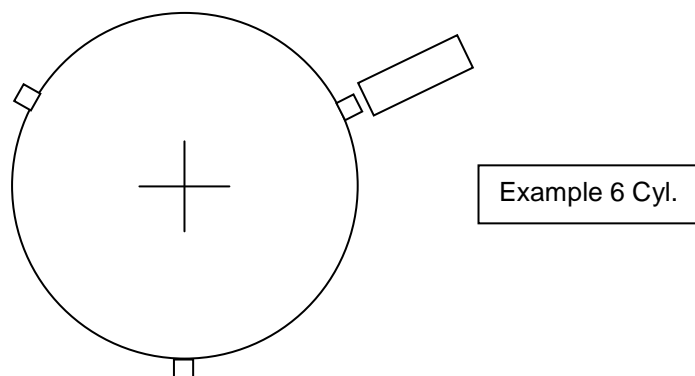

To position the sensor and disc, firstly rotate the engine to approximately 60 degrees BTDC. Then choose where the sensor is to be mounted. At this position one of the lugs on the timing pulley must be facing the sensor. The timing disc is then fixed in that position.

The clearance between the disc and sensor is determined to some extent by experimentation but about 0.5mm is generally satisfactory.

When the engine is running, the option **Delay Angle** is then used to bring the mapped value into line with the real timing value.

### 3.1.3 Distributor Triggering

It is possible to give the engine its speed and position signal through distributor triggering instead of a crank trigger wheel. This option is however difficult to set up and not all distributors are suitable so is not usually advised. If this is the speed sensing used, then the type of sensor required is a Hall Effect sensor.

- Fit the distributor as normal, but with the cap removed
- Rotate the engine to approximately 55 BTDC, firing stroke cyl 1
- With the ECU connected, place a volt meter across the Hall Sensor to read its output voltage
- Rotate (advance) the distributor until the point where there is a change in voltage (this will be a switch from 0v to 5v or 5v to 0v)
- Lock the distributor in this position
- Rotate the engine to 20-30 BTDC
- If the rotor arm is still facing cyl 1 then this should work. If not, the sensor may need to be moved.

The timing now needs to be set as in section 2.7.

## 3.2 Load

The ECU needs an input of engine load. The Omex ECU can use an input of either throttle position or manifold absolute pressure (MAP). Most normally aspirated engines will use an input of throttle position as this gives excellent throttle response. Forced induction engines need to use MAP as there is no direct relationship between throttle angle and engine load due to the variable of boost pressure. However, forced induction still requires throttle position sensor (TPS) input for acceleration fuelling, cranking fuelling, and for idle condition information.

### 3.2.1 TPS

Most throttle position sensors can be used with the Omex ECU. Many engines are fitted with these as standard, but some are fitted with throttle switches which cannot be used. See section 2.4 for setup information.

### 3.2.2 MAP

An external three wire 0 - 5 V output MAP sensor can be used to sense engine load. See section 2.5 for setup information.

## 3.3 Temperature

The air and coolant temperature sensors used by the Omex ECU are resistive sensors. The raw outputs of these sensors are calibrated in the ECU to give the information in a more usable form, °C. This means that not all temperature sensors are compatible with the Omex ECU, so we suggest the use of the Omex approved parts.

### 3.3.1 Air Temperature Sensors

The air temperature sensor (ATS) is used to give the ECU information on the temperature of the inlet air. This allows the user to make corrections to the fuelling and ignition timing. The air temperature should be measured as close to the inlet as possible, preferably in the inlet airbox.

### 3.3.2 Coolant Temperature Sensors

The coolant temperature sensor (CTS) is required to give the ECU information on the temperature of the engine's coolant, allowing the user to set up correction factors for cold starting and running.

## 3.4 Barometric

An external three wire 0 - 5 V output sensor with a full scale of 105 kPa absolute may be fed into the MAP input to measure barometric pressure. The ECU then has automatic corrections based on this data. This is only applicable to normally aspirated engines and is not used on most competition engines.

### 3.5 Oxygen (Lambda) Sensor

An exhaust gas oxygen sensor may be employed to trim the fuelling to maintain a stoichiometric ( $\lambda=1$ ) air/fuel mixture to enable an exhaust catalyst to function efficiently and reliably. Any 4 wire (ie heated) narrow band lambda sensor can be used.

# 4 Ignition

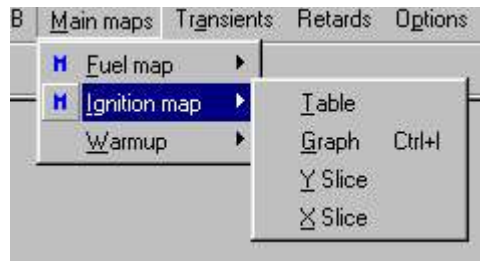

Ignition timing is controlled by a map of numbers. There are 11 load sites and speed sites are at every 400rpm. At each site the timing can be set from 0 to 45 degrees BTDC. Interpolation is used to ensure smooth curves.

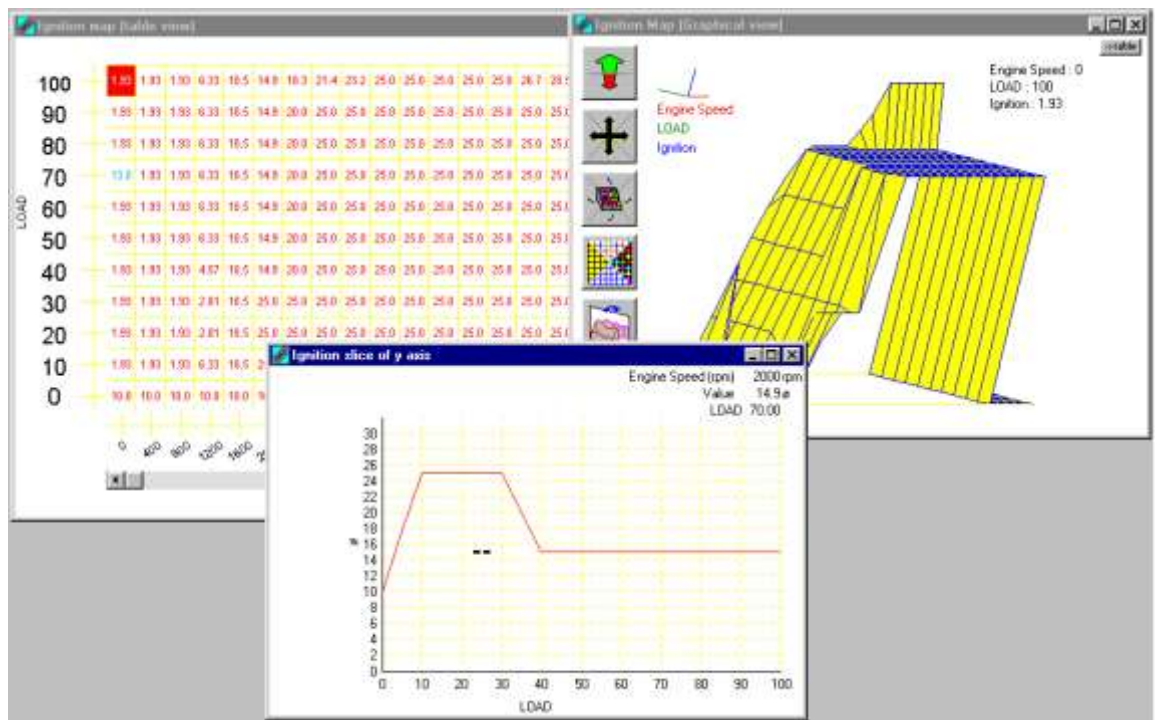

## 5 Fuelling

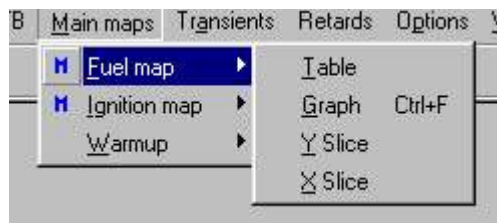

The amount of fuel injected each cycle is dependent on the time the injector is open. This time period (or pulse width) is calculated by the ECU using factors for volumetric efficiency, air temperature, air pressure, cold start enrichment, injector flow rate and battery voltage.

Volumetric efficiency VE, the major factor, is determined by the throttle position (or inlet manifold absolute pressure) as measured with the TPS or MAP sensor, and engine speed using a three-dimensional look-up table. This 3D table is a simple grid with LOAD along one axis and engine speed along the other. It is what is programmed by the user, ie the map.

The LOAD ranges from closed throttle to fully open and is scaled to 100 points. The LOAD axis has 11 sites, one every 10 points from 1 (idle) to 100 (full load). The engine speed axis is divided into sites, one every 400 RPM from 800 to 11200 RPM.

At each intersection of an engine speed site and a throttle position site there is a grid value. This is the volumetric efficiency value or V.E. and is directly proportional to the pulse width and therefore the amount of fuel injected.

These values are determined by running the engine on a dynamometer at each obtainable point and adjusting the VE values to obtain optimum performance. (ie mapping the engine). Values for unobtainable points, such as high speed low load and low speed high load, are normally selected to blend in with the obtainable values.

If the engine is running at an exact engine speed site and an exact throttle position site then the VE value at the intersection of these two sites will determine the amount of fuel injected. If running at a condition where there is no mapped site, the ECU interpolates between the nearest sites.

To successfully map the engine, the following does not need to be fully understood. However, as it explains how the ECU determines the ultimate fuel pulse width from the mapped value it is worth reading. The VE value that you map into the engine is correct for a very basic set of circumstances. To allow for all kinds of other circumstances, such as low battery voltage or low temperature, the VE value is changed by the ECU.

The VE value obtained from the grid is first multiplied by **MSPB** (microseconds/bit), the scaling factor appropriate for the injectors employed and then modified by the operator variable factor **Fuel Mod**, so that;

$$VE(m) = VE \times \mathbf{MSPB} \times \mathbf{Fuel\ mod}$$

**Fuel mod** is set by the operator using the PC during mapping. It is zero in normal use. The user may vary **Fuel mod** to determine the optimum VE values during mapping. Under normal conditions **Fuel mod** = 0, **Fuel mod** has a range of  $\pm 50\%$ .

VE(m) is then modified with factors for air pressure (**Air Pressure F**, if measured), air temperature (**Air Temp F**) a cold start factor (**Cool Temp F**) and a user adjustable overall factor (**Fuel Offset**).

$$VE(c) = VE(m) \times \mathbf{Air\ Press\ F} \times \mathbf{Air\ Temp\ F} \times \mathbf{Fuel\ Offset} \times \mathbf{Cool\ Temp\ F}$$

**Air\_press\_F** and **Air\_tmp\_F** have a range of +/-50% whereas **coolant** has a range of 0 to 250%. The first two factors are calculated using an internal table, but coolant comes from the user defined **Warm-Up** table under the **view** menu.

The final fuel pulse width is then calculated by adding a factor determined by battery voltage (**Batt comp K**). This factor comes from the Battery compensation table, if the option **Bat comp K** is not zero, in which case an internal read only table is used. The characteristics for the injectors should be supplied by the manufacturer. It is recommended to set **Bat comp K** to zero so that the internal table is used, at least initially.

$$\text{FPW (final pulse width)} = \text{Pulse width} + \text{Battery F} + \text{Accel Fuel}$$

This ensures the accuracy of the fuel metering at all battery voltages. Fuelling is inhibited if engine speed is less than the **Min Speed** option or greater than the **Fuel Cut** option.

## 5.1 Injectors

There are two electrical types of injector, high impedance, and low impedance. High impedance is approximately 12 ohms, and low impedance is approximately 3 ohms. The OMEM550 ECU is designed to use high impedance injectors, but can be used with low impedance if ballast resistors are used. The ballast resistors are shown in the wiring diagram.

### 5.1.1 Sizing

Estimation of fuel flow.

$P$  = Anticipated Engine Power in KW (1 BHP=746W or 0.746KW)

$be$  = Specific Fuel consumption in g/KWh ( $g$  =grams)

Fuel flow required =  $P * be$  (in g/h)

For most modern petrol engines, a value of 500g/KWh is a fair assumption. So for a 4 cylinder engine with one injector per cylinder and a peak power output of 60 KW (80 horse power):

$$\begin{aligned} \text{fuel flow} &= 60/4 * 500 = 7500 \text{ g/h} \\ &= 125 \text{ g/min for one cylinder.} \end{aligned}$$

### 5.1.2 Scaling

As a starting point it is quite acceptable to set **MSPB** to 50. This will give a very good starting point for most engine setups. Once a sample full throttle point around maximum torque has been trial mapped, the **MSPB** can be adjusted to give a maximum fuel map setting of 200 or so. The MAP2000 software can do this for you (see MAP2000 Rescale Fuel Map). If however you wish to calculate the **MSPB** before starting, the following gives a method of doing this. If you wish to use maps from other manufacturer's ECUs then set **MSPB** to 100. Then each 0.1 mS is the same as 1 on our map.

The most important variable for fuel is **MSPB** (microseconds per bit) since the fuel pulse width is;

$$\text{Base Fuel Pulse width in microseconds} = VE \times \text{MSPB}$$

VE is the value taken from the fuel map for the particular load and speed. (ie the mapped value).

If the flow rate of the injector for the fuel pressure being used is known then the fuel charge per cylinder may be calculated.

The fuel map resolution is one part in 255. This is not a constraint if full use is made of the available range by selecting a suitable value for **MSPB**, the fuel map scalar.

The fuel injector scaling should avoid continuous flow. (ie map = 255). Assuming an injector flow rate of 200g/min and a fuel flow requirement of 125 g/min for one cylinder. So at maximum engine speed of 6000 rpm;

$$125\text{g per min}/3000 \text{ cycles per min} = 0.042 \text{ g/cycle}$$

If we assume peak power at an engine speed of 6000 RPM, an injection event will occur every 20mSec and require 0.042g per engine cycle per cylinder. Thus the injector on time for 0.042g to be delivered is;

$$(0.042\text{g} \times 60\text{sec}/\text{min}) / 200\text{g} / \text{min} = 12.5 \text{ mSec}$$

Note this pulse width will be displayed by **Pulse width** parameter. The fuel map should be re-scaled for a maximum VE at full load at 6000 rpm of about 200.

Thus to calculate **MSPB** (micro seconds per bit)

$$12500/200 = 62.25 \quad \text{so use } 62.$$

### 5.1.3 Battery Compensation



An injection period is made up physically of 2 time periods. The end period is when the injector is open and flowing fuel, but the first period is when the injector is opening its valve and there is no flow of fuel. At low injector durations, this period where the injector is reacting but not flowing fuel can be significant.

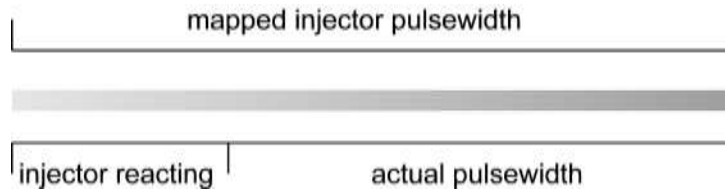

This time period of no flow varies in length with battery voltage and with fuel pressure. This also varies between injector models. Were an engine to run at a constant voltage, then there would be no problems as the injector reaction time would be a constant length. However, the injectors do see a varying voltage so the ECU needs to allow for this varying period of no fuel flow, and as all types of injector react differently, it needs to be told this information by the user. The information is held in the ECU in the **Battery Comp** table and the **Batt Comp K** option. The value of the **Bat comp K** option is the scalar for the **Battery Comp** table.



$$\text{Battery Comp Factor} = \text{Battery Comp table value} \times \text{Bat Comp K option}$$

The battery voltage compensation data can usually be supplied by the injector manufacturers. For example, the Weber IW 058 injector data is for 3bar fuel pressure,

Battery Volts	Offset time mSec
8.0	2.028
10.0	1.217
12.0	0.806
14.0	0.558
16.0	0.391

The Omex ECU can not take the data in the form of offset time in msec. It instead requires the table to hold the data as a number between 0 and 255 which is then scaled by the constant **Batt Comp K**.

It is simplest to use 10 µSec per bit for **Batt Comp K** giving values of,

Battery Volts	Offset time
8.0	203
10.0	122
12.0	81
14.0	56
16.0	39

The missing values for odd voltages are best blended using the graphical display of **View | Battery Comp Table | graph**

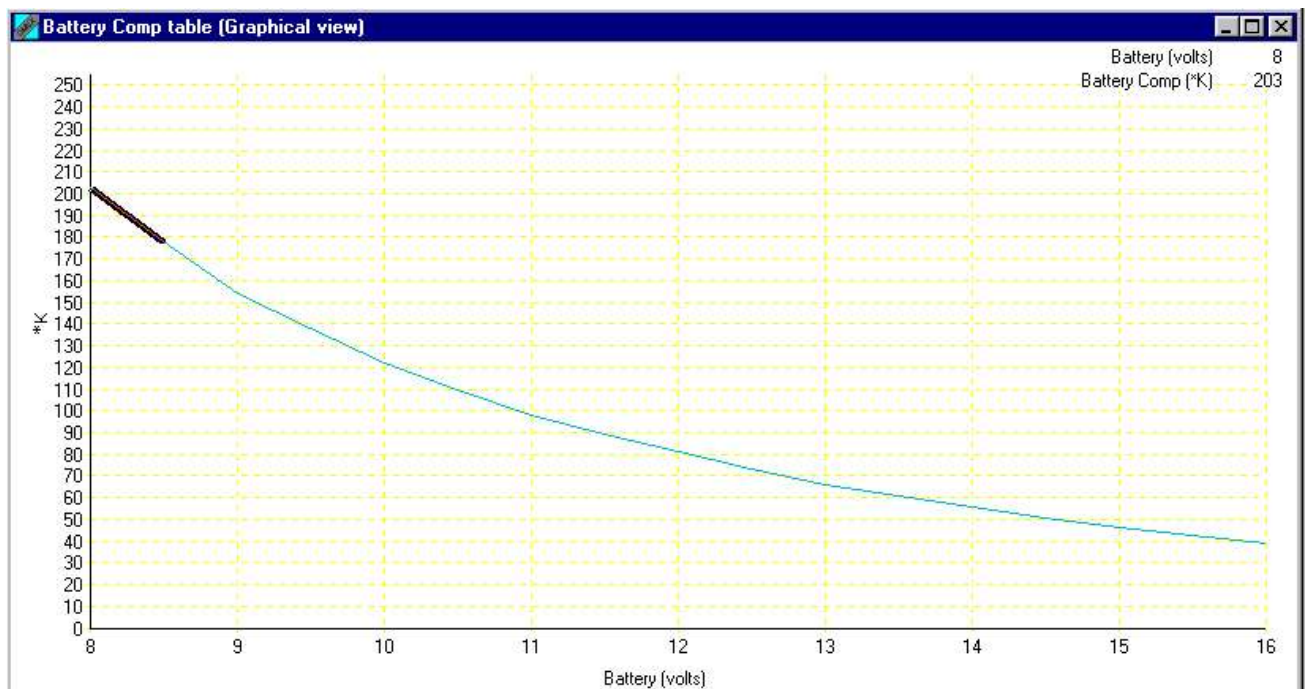

The values for known injectors at 3bar fuel pressure are as follows (assuming a **Batt Comp K** of 10)

IW058 – see above.

IWP043 and IWP069

Battery Volts	Offset time
8.0	190
10.0	119
12.0	82

14.0	59
16.0	42

If this information is unavailable for your injector, then you will need to find these values yourself.

- Connect a power supply to run the injectors and ECU at variable voltages
- Fully map the engine at a normal running voltage
- Find a steady point somewhere off idle eg 10% load 3000 rpm, and note the lambda reading at this point
- Change the voltage of the power supply to one of the voltages on the **Batt Comp table**
- The lambda reading may change. If so, change this voltage's value in the **Batt Comp table** to return the lambda to the original reading
- Repeat this for all of the possible voltages

If a power supply is unavailable, then an attempt can be made to bring down the voltage in road cars by turning on lights, a/c etc.

**Batt Comp K** if set to **0**, gives a preset internal table for battery compensation. The values in this table are not correct for all injectors, so its use should be avoided if possible.

## 5.2 Warm up Fuel



When the engine is cold, it requires an extra amount of fuel. This extra fuel is added as a percentage set in the Warm Up Table of percentage increase against engine coolant temperature.

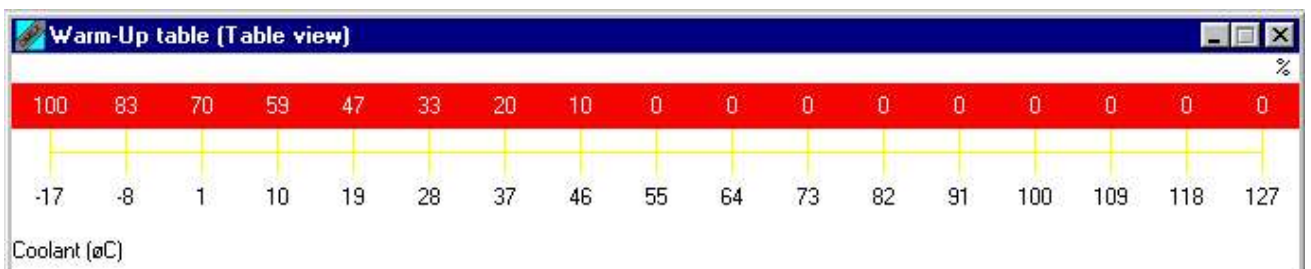

## 6 Oxygen Feedback

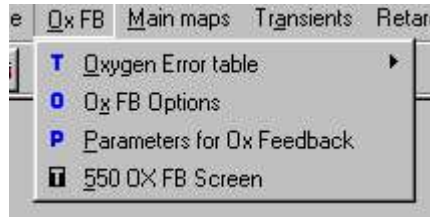

There is a large amount of theory, and many different options, involved in setting up the complicated oxygen feedback as this ECU is capable of meeting very strict emissions requirements. Fortunately, these complicated equations have already been tackled, and nearly all engines require the same settings for oxygen feedback, so it can be set relatively easily.

Firstly we need to check that the sensor is operating correctly

- Open the **OX FB Screen**.
- ECU connect and start the engine, and watch the parameter **Oxygen raw**. Over a few seconds as the sensor warms up, this should start to read a non-zero value. This shows that the sensor is live. The engine may need to be revved to warm up the lambda sensor. Turn off the engine.
- Input the following values to the **Oxygen Error Table**.

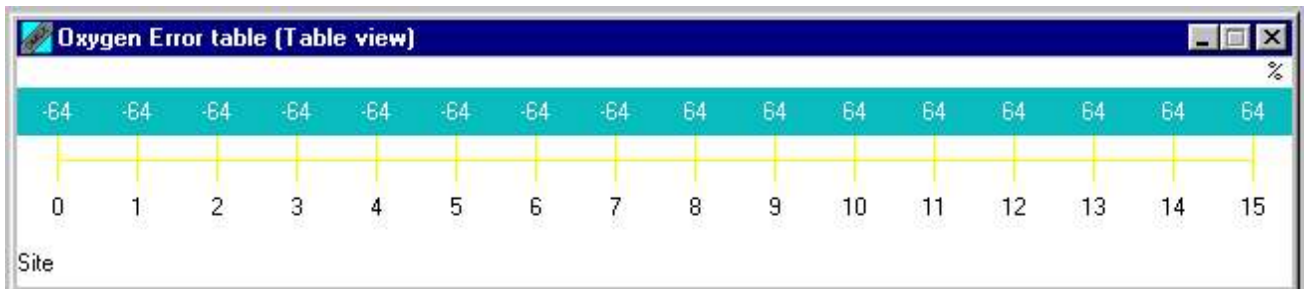

- Input the following options values to the **OX FB Options** window.

Coolant OK	60	°C
Ox FB Load	30	
Ox FB Speed	3500	rpm
OX FB +ve	19.92	%
OX FB -ve	-19.92	%
Stoich	50	
OX FB Gain	2	
OX FB INT	10.00	
OX FB P	5.00	
OX FB Rate	96	mSec
Min Acc Fuel	0	µS
TPS Fullload	90	
Fullload Fuel	0.00	%

- **OX FB Load** and **OX FB Speed** define the conditions where oxygen feedback is active, so these are set to the users requirements for oxygen feedback. The above are typical values to pass MOT and SVA tests.
- Start the engine and watch the parameter **OX Feedback**. This shows the percentage changes to the fuelling the oxygen feedback loop is making.

## 7 Transient Fuelling

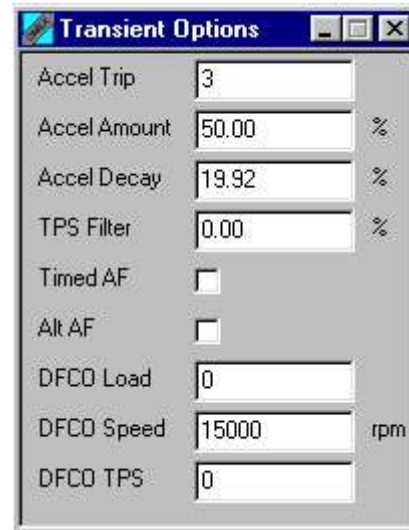

The fuel map contains the fuel for steady state running. Fuel transients such as acceleration and deceleration of the engine especially at gear changes will require different fuelling. To prevent excessively lean or rich stumbles and emission control problems the ECU has two functions; Deceleration fuel cut-off (**DFCO**) and throttle triggered acceleration fuel enrichment (**Accel Trip, Amount & Decay**).

### 7.1.1 Acceleration Fuel

Throttle position is measured every 8 milliseconds. When there is a large change in throttle position, then some additional time is added to the base fuel pulse width to give an extra 'burst' of fuel. The operation sequence is;

when **dTPS +ve > + Accel Trip** option  
then;

$$\text{Accel Fuel} = \text{Accel Fuel} + (\text{dTPS} \times \text{Accel Amount})$$

**Accel Fuel** is decayed every injection event or 8 mSec back-ground event

Therefore;

$$\text{Accel Fuel} = \text{Accel Fuel} \times \text{Accel Decay option}$$

The decision to decay in background or every injection is controlled by the option **Timed AF**. If set then the fixed 8mSec rate is used. These values are best tested in the vehicle.

The filter for TPS allows the magnitude of the change of throttle position to be set so that you can choose what throttle position change triggers acceleration fuelling. With **TPS Filter** set to 0 there is no filtering, however the minimum filter value is 93% with 7% giving maximum filter. This needs to be determined by road or track testing.

### 7.1.2 Deceleration Fuel Cut Off

When this function is active the engine fuel is dropped to a minimum. The trigger conditions for this function are;

- Load < **DFCO load** option
- and **Engine Speed** > **DFCO speed** option
- and **Coolant** > **Coolant OK** option
- and **Throttle** < **DFCO TPS** , (ie) throttle closed

The closed loop oxygen control is inhibited while **DFCO** is active.

## 8 Idle Stabilisation

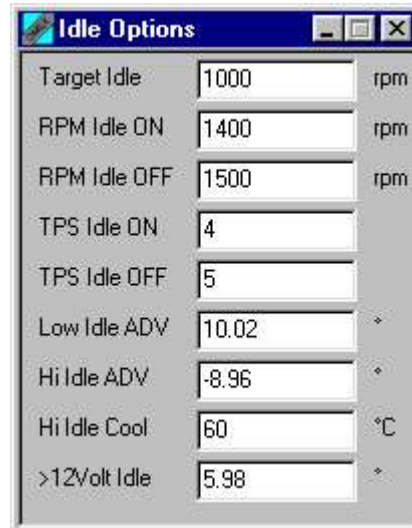

An idle stabilisation algorithm has been included in the ECU to give a stable idle speed by adjusting the idle ignition timing. If the engine falls below the target idle speed, the ignition timing is advanced to accelerate the engine, and if the engine speed is too high the timing is retarded. A good natural idle without the idle stabilisation should be achieved first before enabling the idle stabilisation.

When the engine is at a minimum stable speed the engine is in the idle condition. The entry conditions for idle are:

**Throttle < TPS Idle ON and Engine speed < RPM Idle ON**

The exit conditions from idle are:

**Throttle > TPS Idle OFF and Engine speed > RPM Idle OFF**

The off conditions should be higher than the on conditions.

When in idle the spark advance may be adjusted to compensate for coolant temperature, battery voltage and engine speed.

When in the Idle condition:

**Spark Out = Spark(map) + Idle Spark**

**Idle Spark** is made from:

**Idle Spark** = >12Volt Idle (if **Battery** is less than 12 Volts)  
 + >12Volt Idle (if **Coolant** is less than **Hi Idle Cool**)  
 + **Low Idle ADV** (if **Engine speed** is less than **Target Idle** speed)  
 + **Hi Idle ADV** (if **Engine speed** is greater than **Target Idle** speed)

**Hi Idle ADV** is normally negative to slow the engine.

**Low Idle ADV** is normally positive to accelerate the engine.

## 9 Cranking



### 9.1 Cranking

Whilst cranking, the ignition timing is determined by the **Start ADV** option. This is set in degrees. Typically 2 degrees.

### 9.2 Cranking Fuel

When cranking, the VE value is obtained from the 0 rpm sites and is only variable with throttle position even if MAP is activated.

- **Crank Extra** - This is an additional amount of fuel added, dependent on coolant temperature, while the engine is starting.
- **Crank Decay** - This table determines how quickly the additional crank extra fuel is decayed over time. This decay is a linear decay in seconds after cranking commences.
- **Crank Pulse** - This is a single shot of fuel that may be injected into the engine at Key on, or at the start of cranking if the **Key on pulse** option is set OFF. The value in the table selected dependent on temperature is multiplied by MSPB to give the parameter **Start Pulse** in micro-seconds. For most engines this would not be used.

## 10 Auxiliary Output

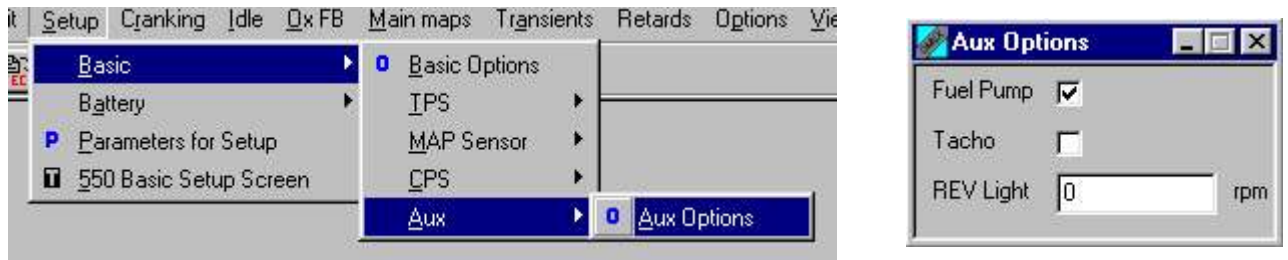

The OMEM550 ECU has a single auxiliary output which can be used as one of three options,

- Fuel pump controller
- Tacho controller
- Shift light output

Which of these is output is set in MAP2000.

The output is a low side switch, so the outputs need to be wired accordingly. Refer to the wiring section for diagrams to show how these are wired. This section also gives details next to the diagrams of the required options settings to enable the outputs.

Although there is only 1 auxiliary output from the OMEM550 ECU, it is possible to have all of these options available as they can be wired in different manners. Each output option can be wired in one of the following ways.

### 10.1 Fuel Pump Controller

- As shown in the wiring diagram, using the ECU auxiliary output
- Wiring through the vehicle's ignition switch

### 10.2 Tacho Controller

- As shown in the wiring diagram, using the ECU auxiliary output
- If single coil, then join the tacho to the coil negative
- If DIS then join the tacho to one of the coil negatives and select the 2cyl setting on the tacho. If unavailable, Omex produce a range of tacho adaptors.

### 10.3 Shift Light

- As shown in the wiring diagram, using the ECU auxiliary output
- Use an Omex stand-alone shift light unit. Contact Omex for details of available units

## 11 Options List

The options would normally be viewed from the menu structure. However, they can be viewed from the view menu. The following list is a reference for what the options do and how they should be set up. The options are ordered as they would appear in the **Options** list if alpha-sort were off.

<b>BAT Comp K</b>	the scaling factor for the battery voltage compensation table. If set to zero then a default internal read only table is used. It is recommended to set to zero unless you have access to the injector characteristics.
<b>Ign Offset</b>	overall ignition map offset, should normally be set to zero.
<b>Fuel Offset</b>	overall fuelling map offset, should normally be set to zero.
<b>CDI Invert</b>	not used. Set to OFF
<b>Double cycle</b>	Omex only. Set to OFF
<b>Always Inj</b>	an injection event every spark event (OMEM550 only. set to OFF)
<b>Rev Inj</b>	an injection event every engine revolution (OMEM550 only. set to OFF)
<b>Cylinders</b>	determines the number of timing input pulses before the output sequence of ignition and injection repeat. Thus in systems with a single timing point per cylinder, this represents the number of cylinders.
<b>MAP min</b>	minimum value of the MAP sensor in normal operation.
<b>MAP max</b>	maximum value of the MAP sensor in normal operation. The raw MAP value parameter is called <b>Pressure RAW</b> .
<b>TPS min</b>	the value of <b>TPS raw</b> required for the ECU to know that the throttle is in the idle (fully closed) position. Set so that <b>Throttle</b> shows 1 at idle.
<b>TPS max</b>	should be programmed with the value of <b>TPS raw</b> at wide open throttle.
<b>LD0MPC</b>	fuel map compression factor used to improve the dynamic range of the fuel map. 255 is an uncompressed map. ALWAYS SET TO 255 WHILST MAPPING.
<b>MSPB</b>	(or microseconds per bit) is the fuel map value scaling factor. This value is dependent upon the size of the injector and the power of the engine. Ideally it should be adjusted so that the maximum value of VE in the VE (fuel map) table is between 200 and 220. A good starting value is 50. (However 100 can make conversion from other systems easier).
<b>Spark Cut</b>	the engine speed at which the ignition cut rev limit commences.
<b>REV Light</b>	the engine speed at which the LED output will come on at if set.
<b>TPS Filter</b>	the filter for amount of the current throttle value. Note if <b>TPS Filter</b> is zero then no filtering is used, (ie the function is disabled). If used, 93% gives the minimum effect, and 7% the maximum
<b>Accel Trip</b>	acceleration fuel enrichment throttle threshold. It is the value that <b>Throttle</b> must change in 8.2 milliseconds to trigger acceleration fuel enrichment. This value can only be determined by track testing. Range 0 to 15. Note zero is non-sensical as it implies the acceleration fuel is triggered with no throttle change.
<b>Accel Amount</b>	the amount of acceleration enrichment fuel added to the base fuel from the fuel map. This value can only be determined by track testing. The value should be set to 0 to disable acceleration fuelling. Typical values are 20 to 70.
<b>Accel Decay</b>	how quickly the acceleration fuel decays away. If set to zero the acceleration fuel would be zero after one injection event, if set to 99% then the acceleration fuel will have a long sustain; typical values are 30-80%.
<b>Pickup Fact</b>	used to compensate for the systems timing pickup and ignition coil delays. All sensors have a small electrical delay that can cause a timing error at high speed. This error is particularly noticeable with magnetic detectors. This error is subtracted from the nominal timing point to give a virtual timing point, so the user need not compensate in their map for this sensor error. This gives a better match between the screen timing figures in the map and what the engine actually does as measured with a timing light. The pickup delay is in units of 2 microseconds. Maximum delay is 511 $\mu$ S, just over half a millisecond. A typical value is 50 $\mu$ Sec.
<b>Start ADV</b>	the ignition advance angle BTDC while cranking. This only applies when the Magnetic option is on. If Magnetic is off, then the starting advance is set with the timing sensor.
<b>Coil Fact</b>	controls the coil charge time. For Omex part OMEM3501 (a typical electronic, low impedance coil), a value of 20 should be used as this will prevent excessive thermal dissipation. However for coils that can not saturate with a normal battery

	supply then this value may be increased up to 255.
<b>Key on Pulse</b>	when set on will turn on the fuel for the Start pulse time to aid starting.
<b>Alt AF</b>	will calculate the <b>Accel Fuel</b> relative to the current fuel pulse rather than an absolute amount independent of engine speed and load. Can be determined by trial only.
<b>Tooth Edge</b>	if set, then the rising rather than falling edge of the input signal is used as the significant edge at 45 degrees BTDC point. This would normally be set OFF.
<b>Magnetic</b>	if set uses a magnetic type input which only uses one edge of the input. Then it will use the starting ignition advance from the <b>Start ADV</b> option settings. Otherwise a logic type input is assumed as obtained from a Hall or Optical sensor. This changes the timing input switching point from the 0.5 volts appropriate for a variable reluctance sensor to 2.2 volts suitable for a logic type sensor.
<b>Tacho</b>	if set the then the auxiliary output will produce a tacho pulse for every timing event. Note that the Tacho will show 3,800 rpm if the engine is stopped and the throttle is at <b>TPS min</b> if <b>Tacho</b> is set. This is a TPS setting aid.
<b>Timed AF</b>	will decay the <b>Accel Fuel</b> over time rather than over engine revolutions. Can be determined by trial only.
<b>MAP for Load</b>	if set, then LOAD will be calculated by scaling the pressure signal <b>with MAP min</b> and <b>MAP max</b> . If a 1 bar sensor is used then with this option set OFF, the ECU will apply automatic barometric compensations.
<b>Fuel Pump</b>	causes the auxiliary output to drive a fuel pump relay rather than a tachometer or shift light function. The fuel pump relay coil winding is grounded by this output line.
<b>Delay Angle</b>	electronic adjustment of timing.
<b>TPS Fulload</b>	the scaled throttle value that if exceeded will disable oxygen feedback and enable the extra full load Fuel, if the engine coolant temperature is fine.
<b>Fulload Fuel</b>	the extra fuel added when the TPS Fulload value is exceeded.
<b>DFCO Load</b>	the maximum load at which the DFCO will still operate. Note that if MAP is used then the scaled throttle must be less than <b>DFCO TPS</b> .
<b>DFCO Speed</b>	the minimum speed at which the deceleration fuel cut-off is still active. To disable DFCO set this to 25,500 rpm.
<b>OX FB Gain</b>	a multiplier applied to the values from the <b>OX Error table</b> to produce the <b>OX error</b> value, this is scaled as a binary mantissa, so 0 gives 1 and 4 give 16.
<b>OX FB Rate</b>	how often the feedback PI loop is run in milliseconds the lower numbers mean faster so the gain may need to be adjusted accordingly. Zero will disable this function giving an <b>OX_Feedback</b> of 0%.
<b>Coolant Ok</b>	the minimum warmed up engine temperature before the deceleration fuel cut-off feature and Oxygen feedback are enabled.
<b>Stoich</b>	is the value of <b>OX raw</b> the raw value of the exhaust oxygen sensor at which the transition between lean and rich occurs. A typical value is 50, but is best found by halving the maximum (rich) value of display variable <b>OX raw</b> . A typical value 35.
<b>OX FB Int</b>	is the oxygen feedback integrator constant.
<b>OX FB P</b>	is the oxygen feedback integrator proportional constant.
	$\text{new OX\_Feedback} = (\text{old OX\_Feedback} + (\text{OX\_Error} \times \text{OX\_FB\_Int}) + (\text{OX\_Error} \times \text{OX\_FB\_P}))$
<b>OX_FB+ve</b>	the limits for oxygen feedback control.
<b>OX_FB-ve</b>	the limits for oxygen feedback control.
<b>Min Acc Fuel</b>	the minimum amount of acceleration fuelling to inhibit oxygen feedback
<b>OX FB Load</b>	load site above which oxygen feedback is inactive
<b>OX FB Speed</b>	speed site above which oxygen feedback is inactive
<b>DFCO TPS</b>	throttle position below which DFCO is active if other conditions allow. Set as throttle closed.
<b>Low Idle ADV</b>	used to stabilise the idle. Usually positive to speed up the engine.
<b>Hi Idle ADV</b>	used to stabilise the idle. Usually negative to slow down the engine.
<b>Target Idle</b>	the desired idle speed when in the idle condition.
<b>&gt;12Volt Idle</b>	will increase the ignition advance in idle if the battery voltage is low.
<b>Hi Idle Cool</b>	if the coolant temperature is below this value then the <b>Idle Spark</b> will be increased by <b>&gt;12Volt Idle</b> degrees.
<b>TPS Idle On</b>	if the <b>Throttle</b> value is below this setting then Idle will be active if engine speed is less than <b>RPM Idle On</b> .

<b>TPS Idle Off</b>	if <b>Throttle</b> exceeds this value then the idle condition is not active.
<b>RPM Idle On</b>	if the <b>Engine Speed</b> is below this setting then Idle will be active if <b>Throttle</b> is less than <b>TPS Idle On</b> .
<b>RPM Idle Off</b>	if <b>Engine Speed</b> exceeds this value then the idle condition is not active.
<b>Max Tooth</b>	Omex only. Set to 65.
<b>Min speed</b>	the minimum engine speed for fuel and ignition to be active. Typically set to 50 RPM.
<b>Fuel Cut</b>	if engine speed exceeds this value then fuelling will cease. This would normally be set to 200 rpm higher than <b>Spark Cut</b> .
<b>Air Rtd Strt</b>	start temperature for ignition retard based on air temperature.
<b>Air Rtd Rate</b>	retard rate 'ignition degrees per degrees centigrade'.
<b>Coolant Rtd</b>	start temperature for ignition retard based on coolant temperature.
<b>C Rtd Rate</b>	retard rate 'ignition degrees per degrees centigrade'.

## 12 Parameters

The parameters window in the software allows the user to see all of the inputs, calculated values, and outputs of the ECU. They would normally be viewed through the set screens in the menu structure. The following are descriptions of the selectable parameters.

Parameter	Output	Range
<b>+ve dTPS</b>	the current positive change in the value of <b>Throttle</b> , used to trigger acceleration fuelling	
<b>Accel Fuel</b>	additional fuel pulse width due to acceleration fuel. In microseconds.	
<b>Air Pressure</b>	barometric air pressure	0-105 kPa
<b>Air Prsr F</b>	barometric correction factor	+/-15%
<b>Air Temp</b>	inlet air temperature in degrees Celsius	
<b>Air Temp F</b>	correction of fuel due to air temperature, and is automatic	+/-30%
<b>Bat Comp F</b>	additional injector open time in $\mu$ Sec due to battery voltage compensation	
<b>Battery</b>	current battery voltage	0-16 volts
<b>Charge Time</b>	coil on time	
<b>Cool Tmp F</b>	correction of fuel due to coolant warm-up	0-250%
<b>Coolant</b>	coolant temperature in degrees Celsius	
<b>Crank Fuel</b>	extra fuel from the <b>Crank Extra table</b>	0-250
<b>Crank Time</b>	the time for which the <b>Crank Extra</b> fuel will be applied. Valid when engine is cranking.	
<b>DEBUG</b>	Omex only	
<b>Dwell</b>	coil dwell in msec	
<b>Engine Speed</b>	engine speed in RPM	Resolution 4 RPM
<b>Error</b>	Omex only	
<b>Fuel(AIT)</b>	fuel pulse after air temperature modifier	0-131,070 $\mu$ S
<b>Fuel (baro)</b>	fuel pulse after barometric modifier if required	0-131,070 $\mu$ S
<b>Fuel (Fmod)</b>	fuel pulse after <b>Fuel mod</b>	
<b>Fuel (Ld)</b>	after the load factor from <b>LD0MPC</b> is applied	
<b>Fuel (map)</b>	fuel pulse from the map value	
<b>Fuel (Ox fb)</b>	after Oxygen feedback applied	0-131,070 $\mu$ S
<b>Fuel (warm)</b>	after warm-up modifier	0-131,070 $\mu$ S
<b>Fuel mod</b>	parameter that is affected by the <b>trim control (virtual potbox)</b> to vary the current fuelling	$\pm$ 50%
<b>Idle Spark</b>	spark modifier due to idle condition	
<b>LOAD</b>	engine load used for maps	0-100
<b>MAP AS LOAD</b>	MAP signal scaled for load	0-100
<b>Ox Error</b>	error signal from the oxygen error table	
<b>Ox Feedback</b>	output of the PI loop	+/-50%
<b>Ox History</b>	the bit pattern history of <b>OX raw</b> transitions	
<b>Oxygen raw</b>	unscaled amplified oxygen signal	0-255
<b>Pressure raw</b>	unscaled MAP/BAR	0-255
<b>Pulse width</b>	final fuel pulse width including any crank extra. i.e. the actual output	
<b>Spark (mod)</b>	spark timing after <b>Spark mod</b>	
<b>Spark adv</b>	current ignition advance map value	0 to 45°
<b>Spark mod</b>	parameter that is affected by the <b>trim control (virtual potbox)</b> to vary the current spark advance	$\pm$ 22.5°
<b>Spark out</b>	includes any Idle Spark timing. i.e. the actual ignition timing	
<b>Spark Rtd</b>	ignition retard based on temperature	
<b>Start Pulse</b>	one shot fuel pulse to aid starting in $\mu$ Sec	
<b>Throttle</b>	scaled throttle signal	0-100
<b>Timer</b>	Omex only	
<b>TPS raw</b>	unscaled throttle position sensor	0-255
<b>VE(MAP)</b>	current fuel table value	0-255
<b>VExFMOD</b>	current fuel modified by <b>FMOD</b>	0-255

## 13 Wiring

### 13.1 Semi Assembled Loom Construction

It is vital that the wiring loom is well terminated and fitted and can meet all normal running conditions.

- The wires must be crimped to the connector inserts with a suitable tool. Additional soldering is a bonus. Where possible strain relief clamps should be employed to retain the insulation.
- Cables of adequate current carrying capability must be used. High pressure fuel pumps can draw up to 15 Amps. Ignition coils can draw up to 10 Amps. Low impedance injectors up to 5 Amps. If the cable runs are long, as found in the dynamometer environment, then thicker conductors must be used to compensate for the increased length.
- Clamp the cables within a sheath to stop the cables flapping and adding additional stress to the wire joints. When fitting the harness into the car, ensure it is well cable tied onto suitable mounting points. Make sure that suitable grommets are fitted wherever the harness is fitted through panels. Do not bend the harness through very tight radius bends.
- Use suppressed ignition leads on distributor based systems. A suppressed king lead is usually all that is necessary to protect the system. Do not use solid copper leads under any circumstances.

## 13.2 Component Pin-outs

<b>Throttle Position Sensors (TPS)</b>			
<b>Omex Part Number</b>	<b>Description</b>	<b>Pins</b>	<b>Omex Wire Colour</b>
OMEM2001	General Purpose	1 Signal (green) 2 +5v (red) 3 Sensor Earth (Black)	Orange Pink Grey
OMEM2002 OMEM2003	DCOE Carbs	1 Signal 2 Sensor Earth 3 +5v	Orange Grey Pink
OMEM2004	DHLA Carbs	1 Signal 2 Sensor Earth 3 +5v	Orange Grey Pink
OMEM2005	Jenvey	1 Signal (red) 2 +5v (Green) 3 Sensor Earth (yellow)	Orange Pink Grey

<b>MAP Sensors</b>			
<b>Omex Part Number</b>	<b>Description</b>	<b>Pins</b>	<b>Omex Wire Colour</b>
OMEM2100	1 Bar	1 Signal	Green
OMEM2102	2 Bar	2 Sensor Earth	Grey
OMEM2103	3 Bar	3 +5v	Pink

<b>Coils</b>			
<b>Omex Part Number</b>	<b>Description</b>	<b>Pins</b>	<b>Omex Wire Colour</b>
OMEM3501	4 Cyl DIS	1 Ign 1 2 Ign 2 3 +12v Supply 4 n/f	Violet Yellow Switched
Ford Coil	4 Cyl DIS 3 pin	1 Ign 1 2 +12v 3 Ign 2	Violet Switched Yellow

<b>Temperature Sensors</b>			
<b>Omex Part Number</b>	<b>Description</b>	<b>Pins</b>	<b>Omex Wire Colour</b>
OMEM2200	Coolant Temp (CTS)	1 Sensor Out 2 Sensor Earth	Green / Blue Grey
OMEM2201	Air Temp (ATS)	1 Sensor Out 2 Sensor Earth	Green / White Grey

<b>Crank Position Sensors (CPS)</b>			
<b>Omex Part Number</b>	<b>Description</b>	<b>Pins</b>	<b>Omex Wire Colour</b>
OMEM2400	Cylindrical	1 Sensor Out 2 Sensor Earth	Red Screened Black Screened
OMEM2401	2 hole mounting	1 Sensor Out 2 Sensor Earth	Red Screened Black Screened

<b>Oxygen (Lambda) Sensors</b>			
<b>Omex Part Number</b>	<b>Description</b>	<b>Pins</b>	<b>Omex Wire Colour</b>
	4 wire	Sensor Out (Black) Sensor Earth (Grey) Heater (White) Heater (White)	White / Red Grey +12v Switched Earth

### 13.3 ECU Pin-outs

It is occasionally necessary whilst fault finding to trace through your wiring harness to check continuity. The following are the pin-outs for the ECU plug as found on the end of the wiring harness.

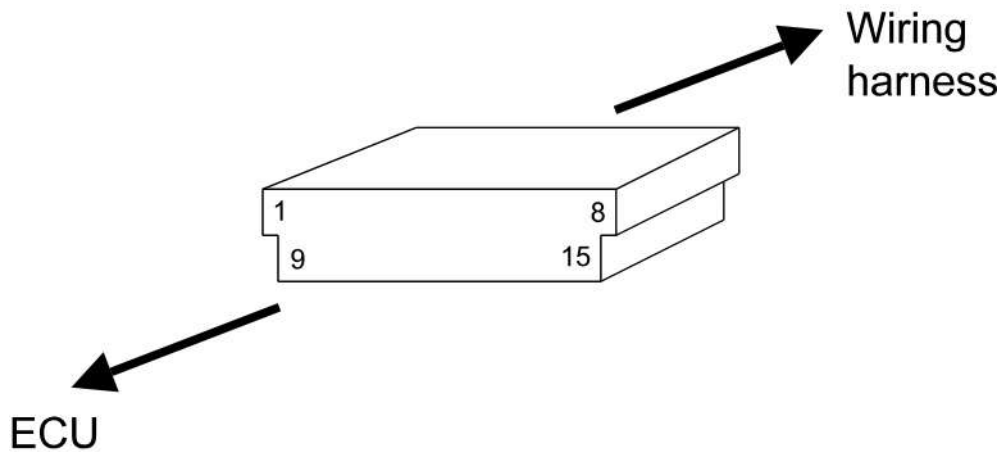

Pin	Colour code	Function
1	yellow	ignition driver 2 output
2	screened red	timing (CPS) pickup input
3	blue	auxiliary output
4	orange	throttle position sensor wiper input
5	pink	+5v sensor power output
6	brown	injector driver 1 output
7	green / white	air temperature sensor input
8	violet	ignition driver 1 output
9	white	injector driver 2 output
10	orange / white	oxygen sensor (lambda) input
11	green / blue	coolant temperature sensor input
12	green	MAP sensor input
13	grey	sensor returns
14	red	power input
15	black	power return

### 13.4 Wiring Diagrams

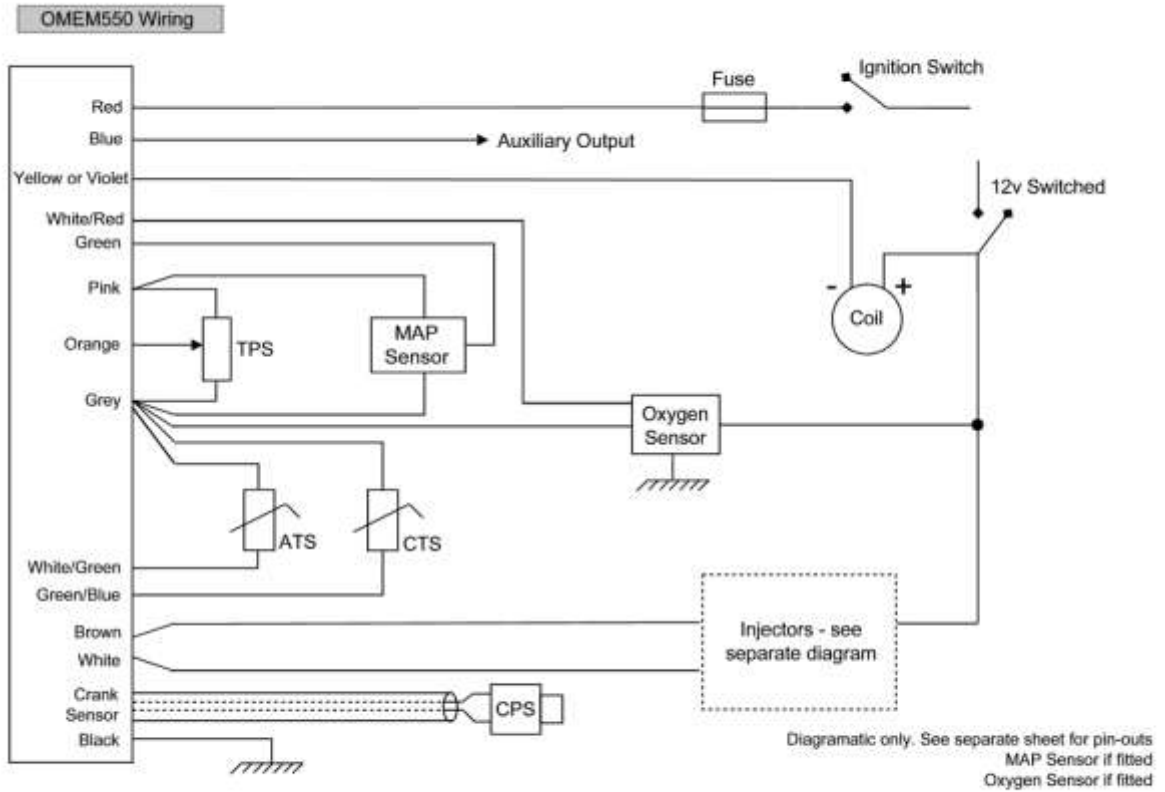

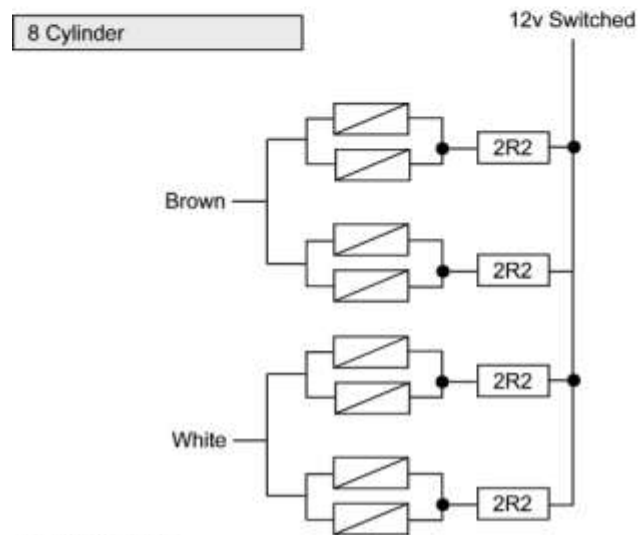
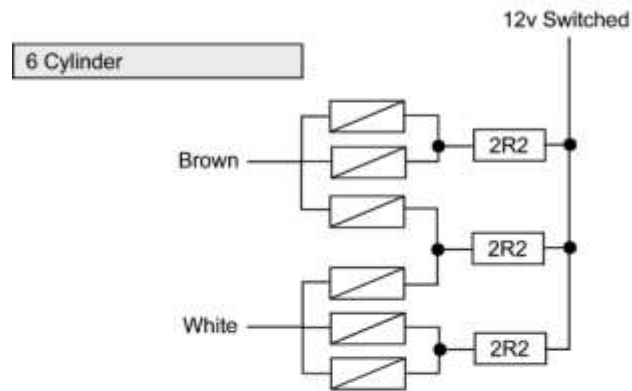
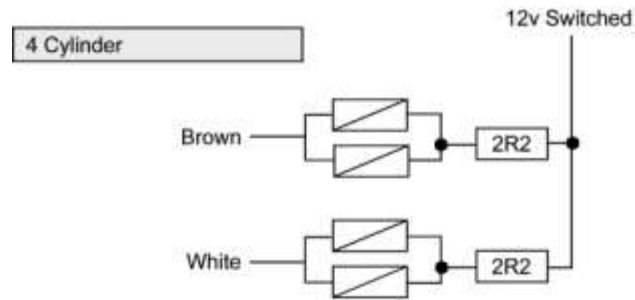

2R2 only if required  
 Cylinder numbers not needed due to batch firing, though easiest to wire drivers as 'banks'

**OMEM550 Auxiliary Output Wiring**

**Fuel pump control**

Fuel Pump - ON  
Tacho - OFF  
Rev Light - 0

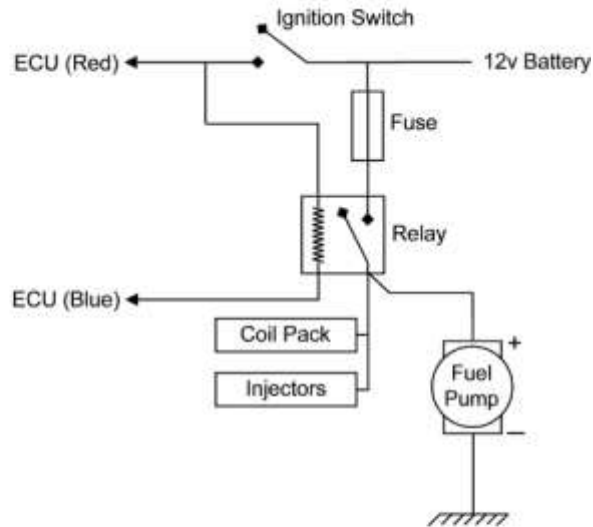

**Tachometer output**

Fuel Pump - OFF  
Tacho - ON  
Rev Light - 0  
1K not always required

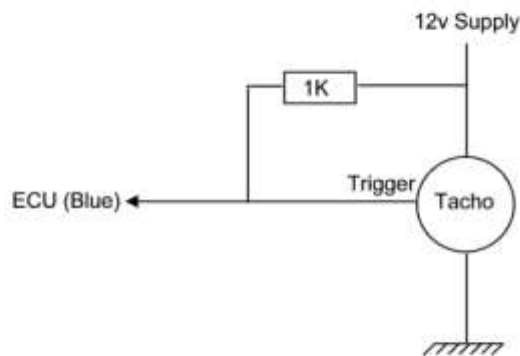

**Gear Shift Light Output**

Fuel Pump - OFF  
Tacho - OFF  
Rev Light - [set to required rpm]

